

Bid Tab

1806 - Southgate, Industrial, and Town Concrete Projects

4/10/2018

	Quantity	Cost per Item	Total Cost
Traffic Control	1 LS	\$/LS	
R&R Sidewalk Concrete 6"	711 sf	\$/sf	
R&R Sidewalk Concrete 4"	1628 sf	\$/sf	
C&G - L Type	224 lf	\$/lf	
C&G - Roll Curb	139 sf	\$/sf	
Driveway AC 3" PG64-28NV Residential	352 sf	\$/sf	
R&R AC 3" PG64-28NV Commercial	60 sf	\$/sf	
Overexcavate 6" Base Remove and Replace	64 cy	\$/cy	
Median Curb up to 6" High	252 lf	\$/lf	
Landscape, Pavers, and Irrigation Repair	1 LS	\$/LS	
Set Bollard Base (Town Provided)	1 EA	\$/EA	
Sinkhole Repair	1 LS	\$/LS	
Reset Meter Box In Spandral	1 EA	\$/EA	
Truncated Dome 4'x2'	12 EA	\$/EA	

Contractor Company:

Total Bid:

Contractor Name:

Contractor Signature:

Date:

Construction Notes:

Construction standards to be followed per Douglas County and Orange Book.
 Work between 7am and 7pm.
 Cleanup after operation each day.
 Noticing of impacted residents 72 hours in advance.
 Traffic Control as required per MUTCD

General Notes:

Engineers Estimate is \$49,204.50
 Not a Prevailing Wage Job.
 Questions will be answered as they are received.
 April 25th at 3:30PM - Bids Due
 May 1st, 2018 at 4:30PM - Award Bid
 July 31, 2018 - Expected Substantial Completion
 Proof of liability & workers comp insurance is required.
 Liability Insurance will name the Town of Gardnerville as additionally insured.

BFI

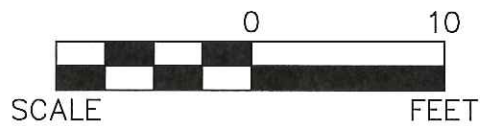
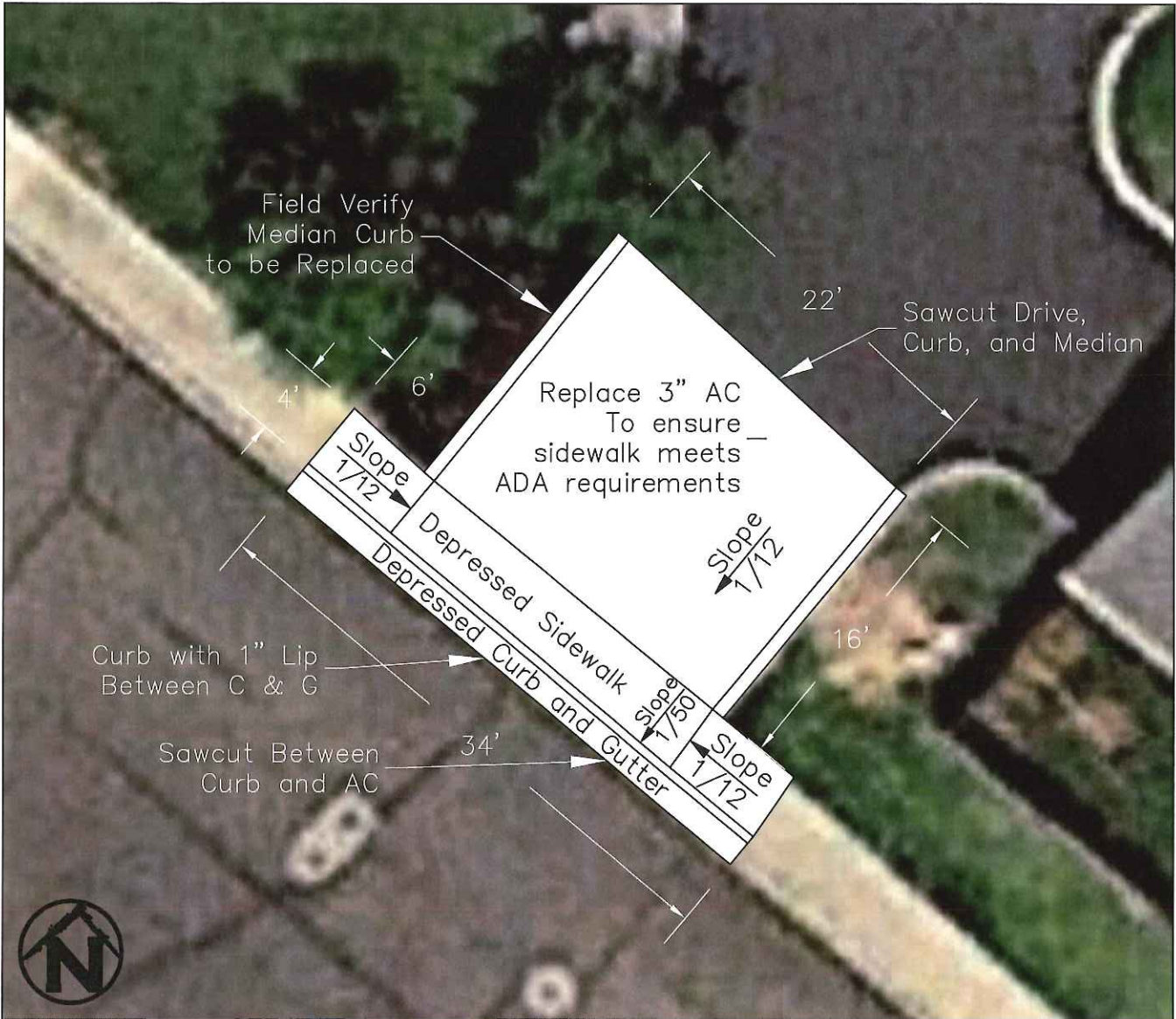

1481 Douglas Ave

Driveway AC 3" PG64-28NV Resid. 22x16	352 sf
R&R Sidewalk Concrete 6" 34*4	136 sf
C&G - L Type	34 lf
Overexcavate 6" Base Remove and Replace	7 cy
Median Curb 6" (Sides of Driveway)	32 lf



TOWN OF GARDNERVILLE
 1481 Douglas Ave
 Gardnerville NV 89410

SECTION: **PAGE 1**
 DATE: **4/10/2018**
 DWG:

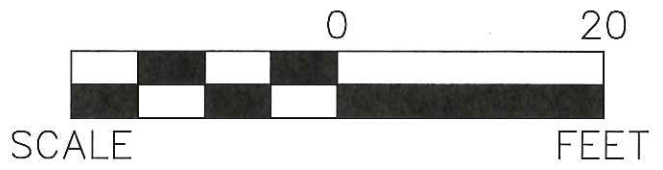
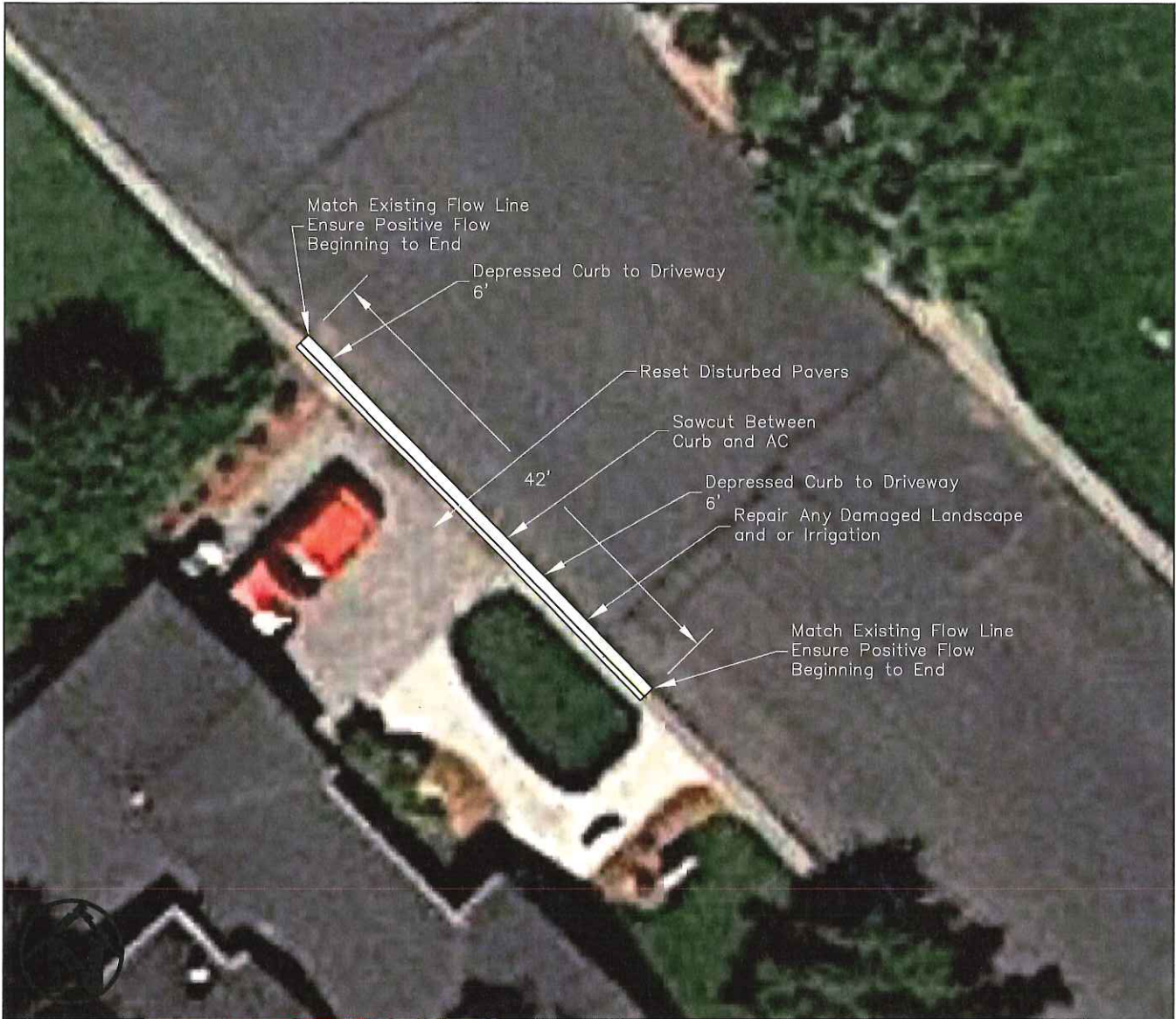

1524 Gardner Dr.	
C&G - L Type	42 lf
Overexcavate 6" Base Remove and Replace	1.5 cy
Landscape, Drive, and Irrigation Repair	1 LS

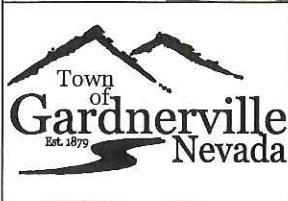

TOWN OF GARDNERVILLE
 1524 Gardner Dr.
 Gardnerville NV 89410

SECTION: *PAGE 2*
 DATE: 4/10/2018
 DWG:

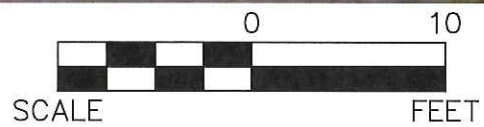
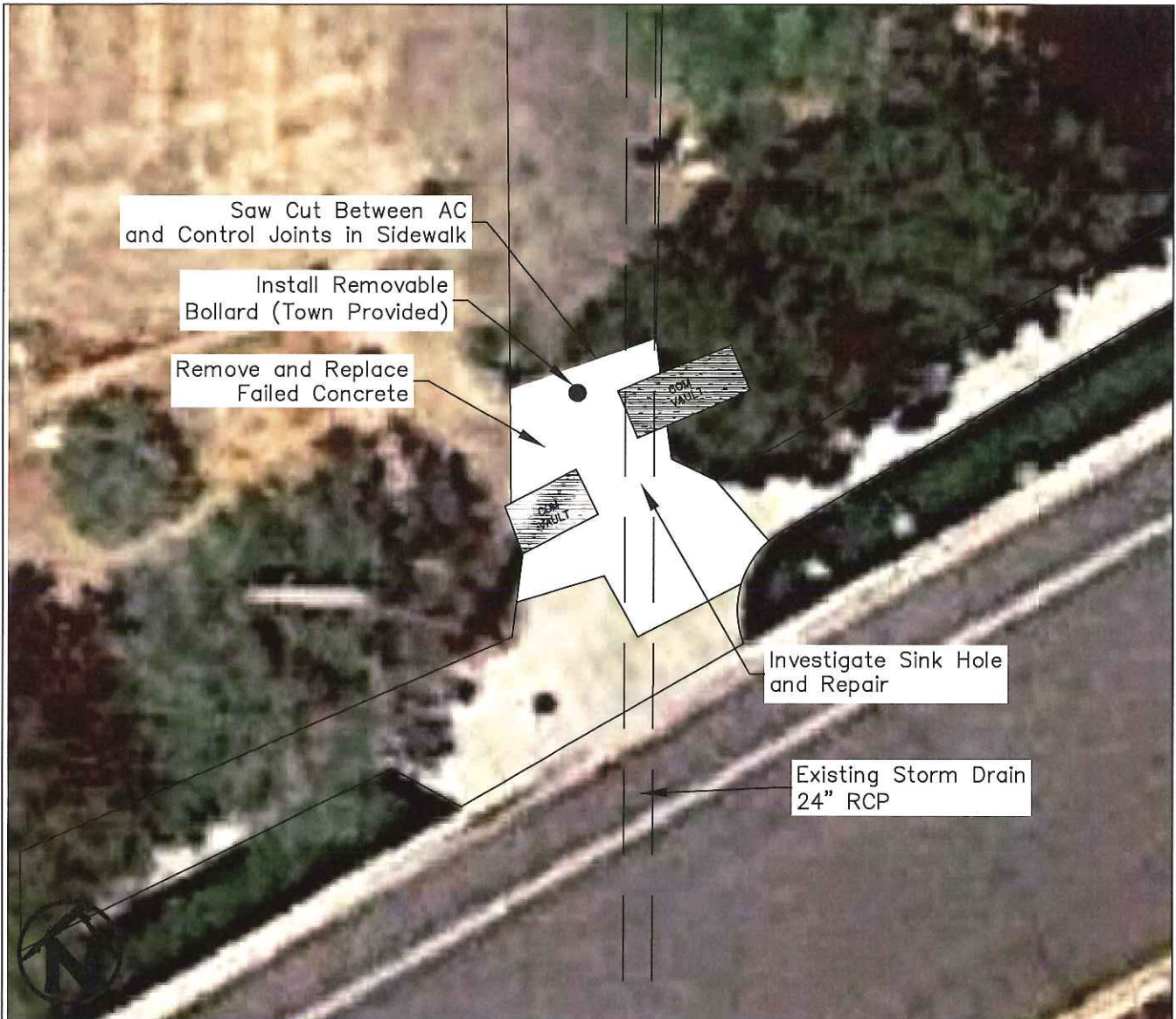

Stodick/Elges Path

R&R Sidewalk Concrete 4"	Irregular	250 sf
Base 12" Replace		10 cy
Set Bollard Base (Town Provided)		1 EA
Sinkhole Repair		1 LS



TOWN OF GARDNERVILLE
 Stodick Parkway and Elges Path
 Gardnerville NV 89410

SECTION: *PAGE 3*
 DATE: 4/10/2018
 DWG:

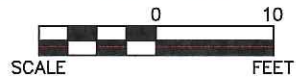
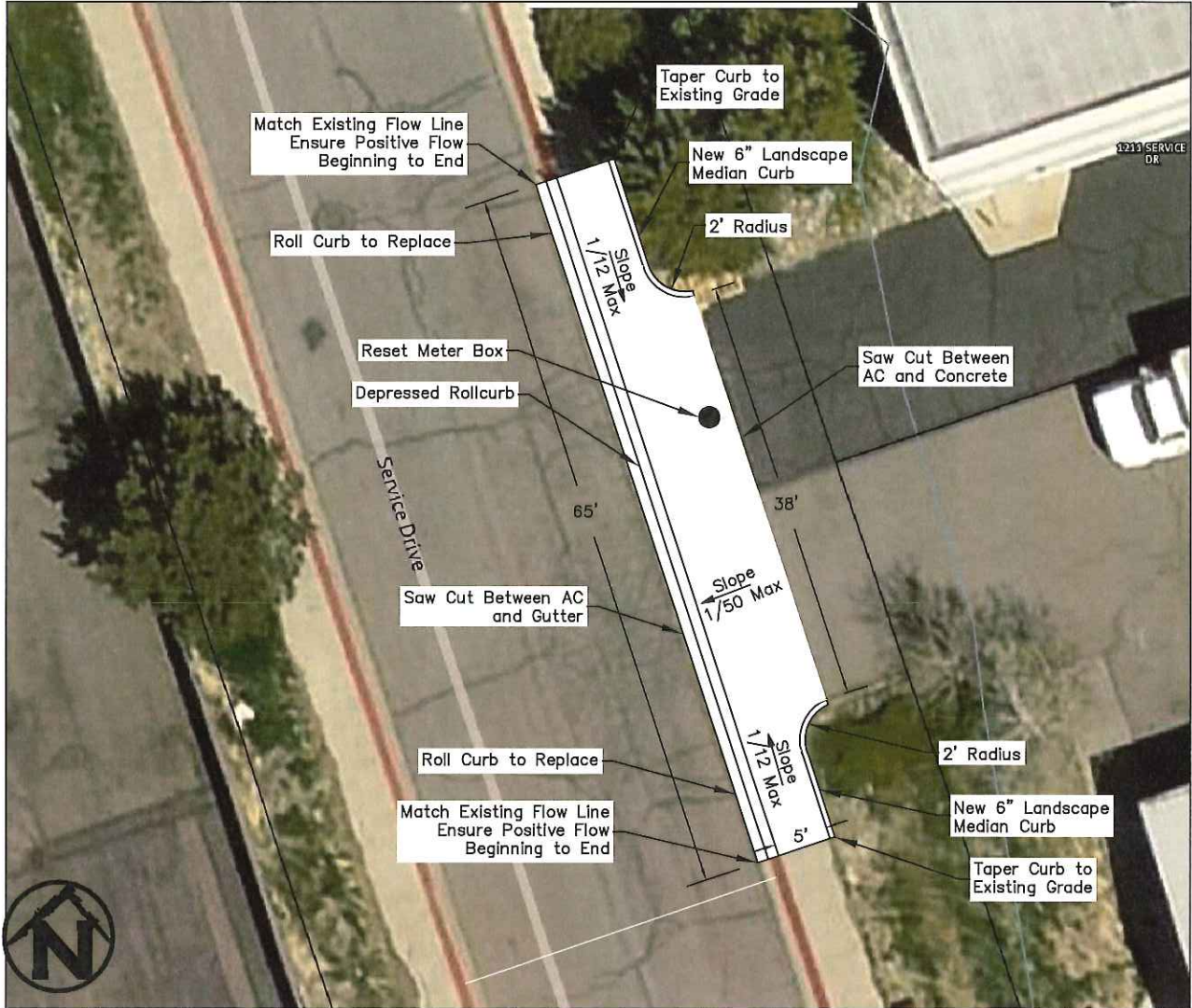

1211 Service Drive

R&R Sidewalk Concrete 6"	5*65	325 sf
R&R Sidewalk Concrete 6"	4*40	160 sf
Median Curb 6"		28 lf
C&G - Roll Curb		65 lf
Reset Meter Box In Spandal		1 EA
Overexcavate 6" Base Remove and Replace		10 cy



TOWN OF GARDNERVILLE
 1211 Service Drive
 Gardnerville NV 89410

SECTION: *PAGE 4*
 DATE: 4/10/2018
 DWG:

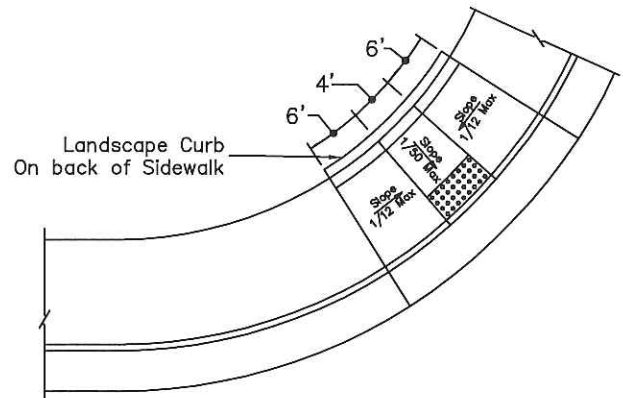
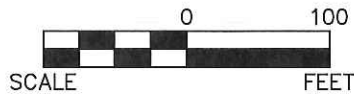

ADA Handicap Ramp



Southgate ADA Handicap Ramps

R&R Sidewalk Concrete 4"	4*16	512 sf
C&G - L Type		64 lf
C&G - Roll Curb		64 lf
Median Curb (on back of depressed ramp)		128 lf
Overexcavate 6" Base Remove and Replace		20 cy
Truncated Dome 4'x2'		8 EA



TOWN OF GARDNERVILLE
 SOUTHGATE DRIVE
 Gardnerville NV 89410

SECTION: *PAGE 5*
 DATE: 4/10/2018
 DWG:

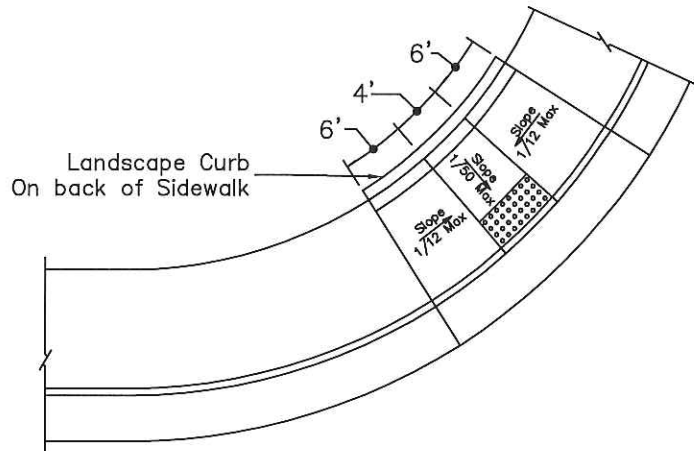
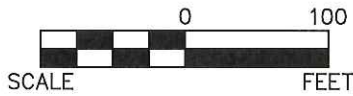
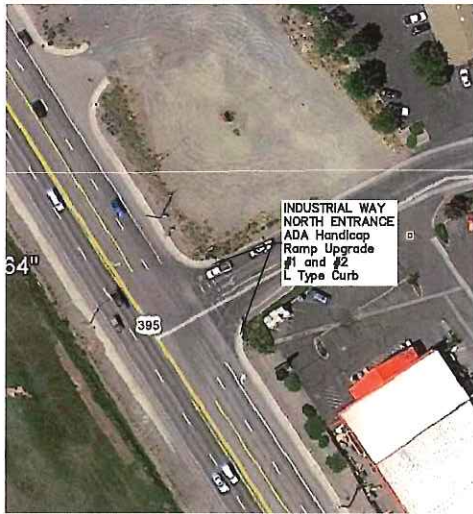

Industrial & 395 ADA Handicap Ramps

R&R Sidewalk Concrete 4"	4*16	256 sf
C&G - L Type		64 lf
Median Curb (on back of depressed ramp)		64 lf
Overexcavate 6" Base Remove and Replace		10 cy
Truncated Dome 4'x2'		4 EA



TOWN OF GARDNERVILLE
 INDUSTRIAL WAY
 NORTH AND SOUTH ENTRANCES
 Gardnerville NV 89410

SECTION: *PAGE 6*
 DATE: 4/10/2018
 DWG:

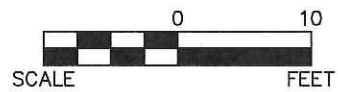
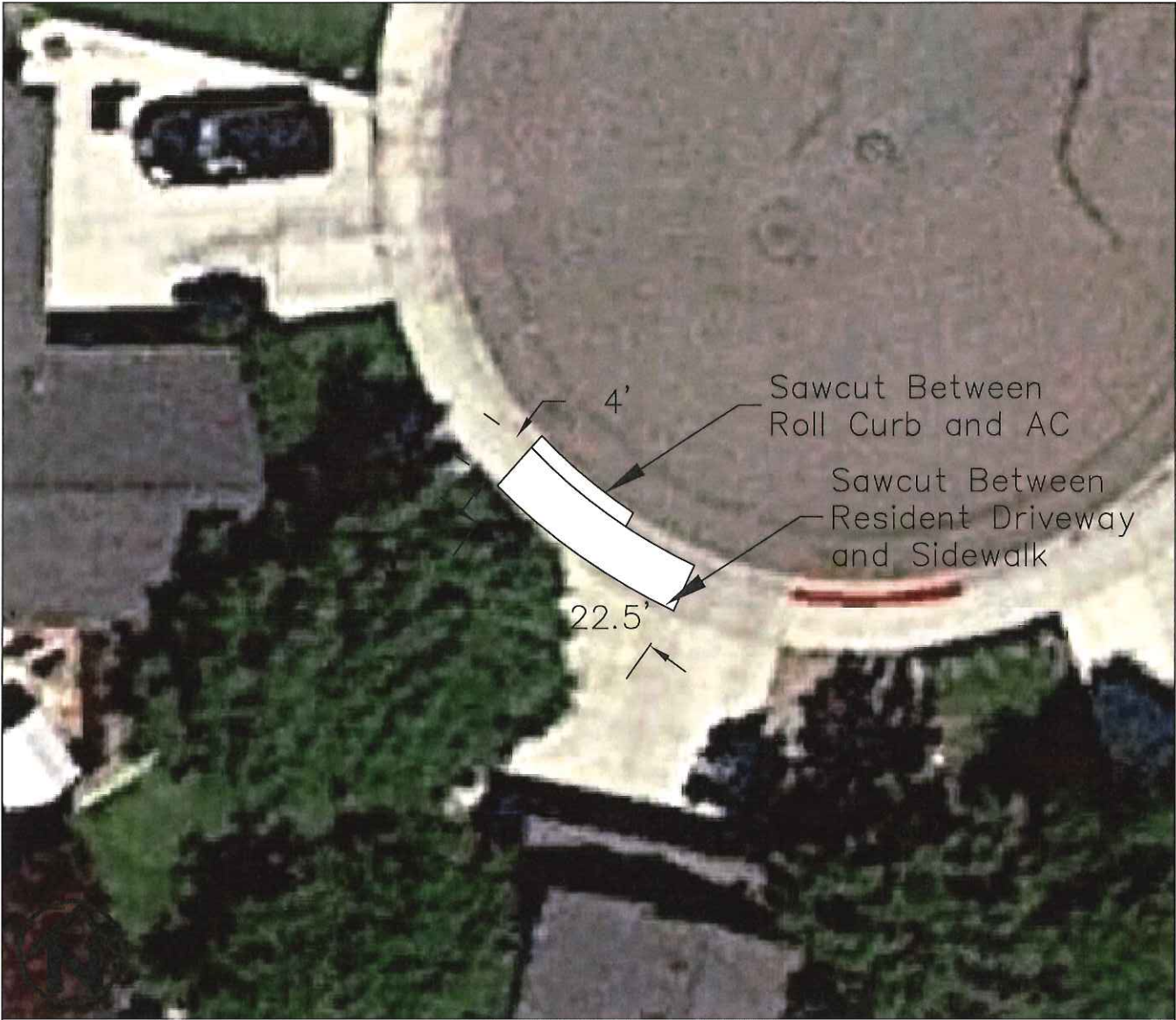

1434 Wendover Ct

R&R Sidewalk Concrete 6"	22.5x4	90 sf
C&G - Roll Curb		10 lf
Overexcavate 6" Base Remove and Replace		2 cy



TOWN OF GARDNERVILLE
 1434 Wendover Ct.
 Gardnerville NV 89410

SECTION: *PAGE 7*
 DATE: 4/10/2018
 DWG:

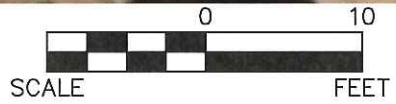

1419 Arlen LN

C&G - L Type

19.5 lf

Overexcavate 6" Base Remove and Replace

1 cy



TOWN OF GARDNERVILLE

1419 Arlene Ct.
Gardnerville NV 89410

SECTION:

PAGES

DATE:

4/10/2018

DWG:



Replace AC for
ADA access around
the Storm Drain

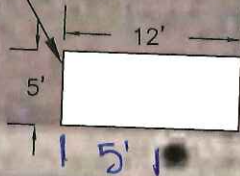

1412 Industrial Way

R&R AC 3" PG64-28NV Commercial 12*5

60 sf

Overexcavate 6" Base Remove and Replace

2 cy



TOWN OF GARDNERVILLE

1412 Industrial Way
Gardnerville NV 89410

SECTION: *PAGE 9*

DATE: 4/10/2018

DWG:

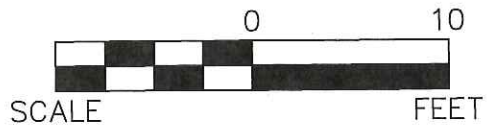

Corner of Carrick and Service

R&R Sidewalk Concrete 4"	12*7	110 sf
Overexcavate 6" Base Remove and Replace		1.5 cy



TOWN OF GARDNERVILLE
 Corner of Carrick and Service
 Gardnerville NV 89410

SECTION: *PAGE 10*
 DATE: 4/10/2018
 DWG:

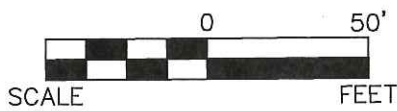
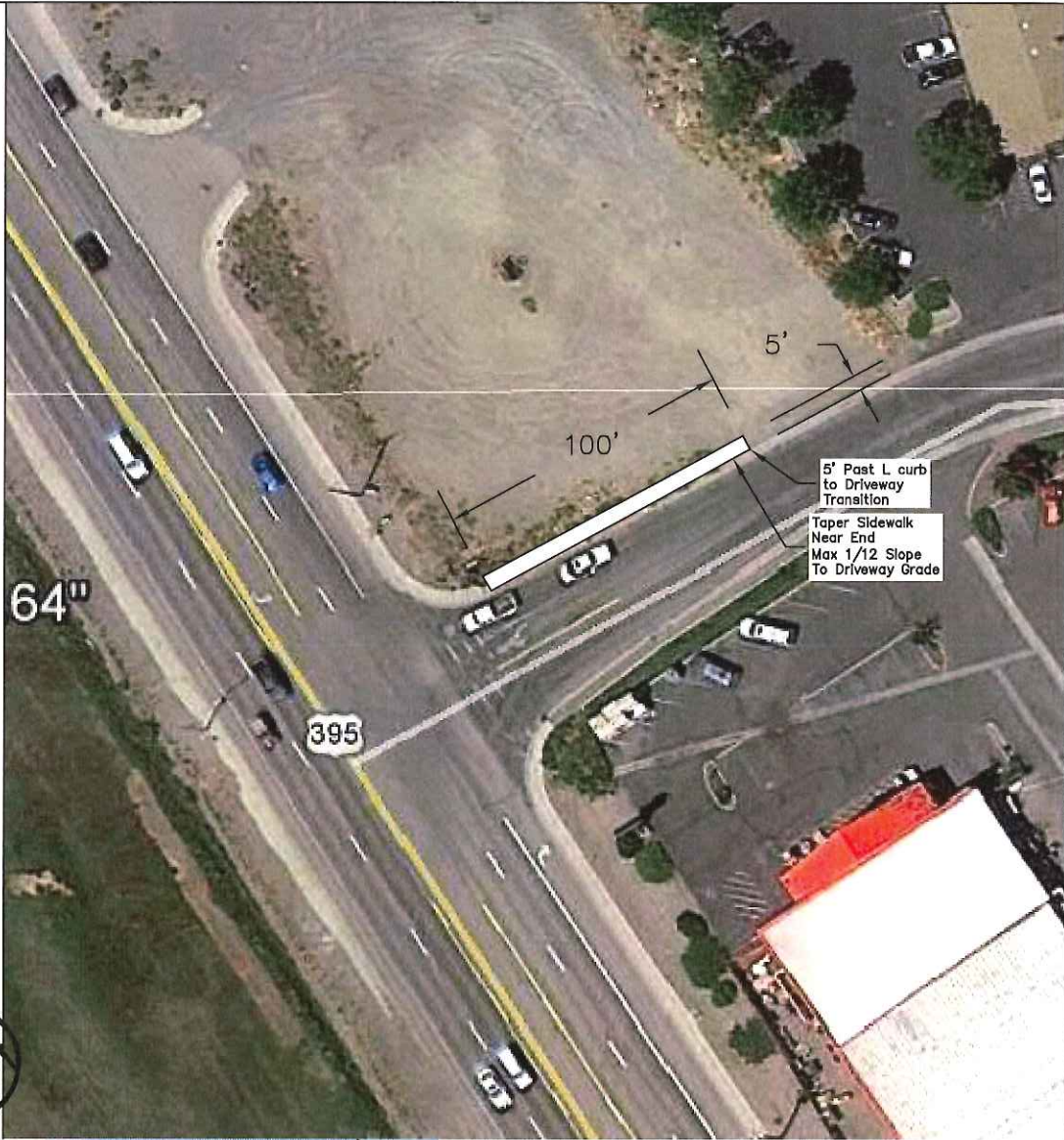

1404 Industrial Way (Corner 395 to address)

R&R Sidewalk Concrete 4"	100*5	500 sf
Overexcavate 6" Base Remove and Replace		9 cy



TOWN OF GARDNERVILLE

1404 Industrial Way
Gardnerville NV 89410

SECTION:

PAGE 11

DATE:

4/10/2018

DWG:

